

*inspired by  
craftsmanship*

## ***Spectra***

Multifunctional CNC working centre  
for window and door manufacturers



## Multifunctional CNC working centre

- for full machining of windows and doors components
- for milling and drilling operations on profiled components

CNC working centre SPECTRA covers whole spectrum of machining operations of straight or curved pieces for windows and doors. The machine is intended as a small working centre for full machining of four knock down components at the same time or as amendment to the angular machining centre for milling and drilling operations, rebate change profiling etc.

The SPECTRA's robust machine construction, powerful drive units, intelligent user-friendly software and perfect ergonomics jointly contribute to meeting the customer's highest expectations regarding performance and flexibility.

## SPECTRA in addition to an angular machining centre

The connection of a separate SPECTRA machine to an angular machining centre is an indelicate combination of performance and complete machining of window and door components. While the angular center efficiently performs tenoning and profiling operations, the SPECTRA machine will drill or mortise muntin bars joints and do milling operations for hardware, hinges, door lock etc. Composition of the machine enables to make arched structures. Machine is dedicated to work from top and back side, with aggregates also to both heads of components.

### Machine configuration

- 8/9,5 kW main electro spindle
- fixed position for working aggregates in 90°
- multifunctional drilling head
- 2 horizontal milling units
- 3 working tables with 4 pneumatic clamps
- 6 positions linear toolchanger

Intuitive control of the machine is provided by a Beckhoff PC with 15" touch screen which uses data from WinCreator or third-party software where machining and all macros are defined. Spectra can be linked to the main angular machine from which identification labels can be printed out allowing the drilled pieces to be scanned and processed at the next stage.



SPECTRA with optional as a multifunctional CNC working centre

## SPECTRA as a multifunctional CNC working centre

The machine SPECTRA can independently provide full machining of windows and doors components and is an ideal solution for manufacturers looking for bespoke projects. The machine is equipped with 4 working tables with clamps for machining up to 4 pieces at the same time. The machine is easily set to do also arches, where the original solution makes this work easier and reliable. The CNC working features enable making different rebates on one piece to make opening/fixed glazing or inward/outward opening.

### Machine configuration

- 8/9,5 kW main electro spindle
- C-axis for working aggregates
- multifunctional drilling head
- 2 horizontal milling units
- 4 working tables with 10 pneumatic clamps
- 12 positions carousel toolchanger
- aggregate holder

Vertical electro spindle HSK-F63  
(C-AXIS for aggregates – optional)  
Vertical five spindle boring head

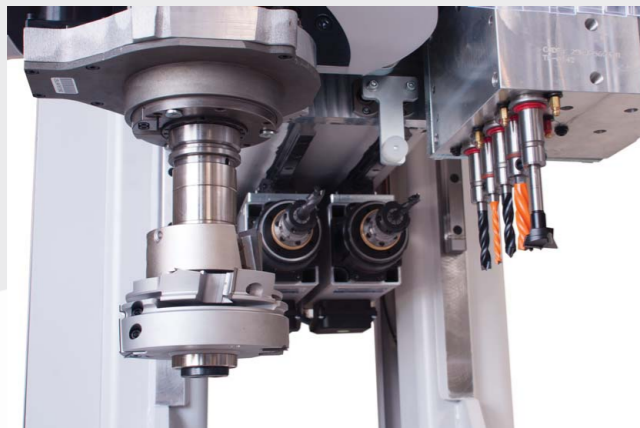

Two horizontal milling units with HSK 40A quick change system



Linear tool changer for 6 tools



Carousel toolchanger with 12 position (optional)  
Holder for a working aggregate (optional)



Four manually moveable working tables with 10 pneumatic clamps for machining of 4 components at the same time and for arches (Optional)

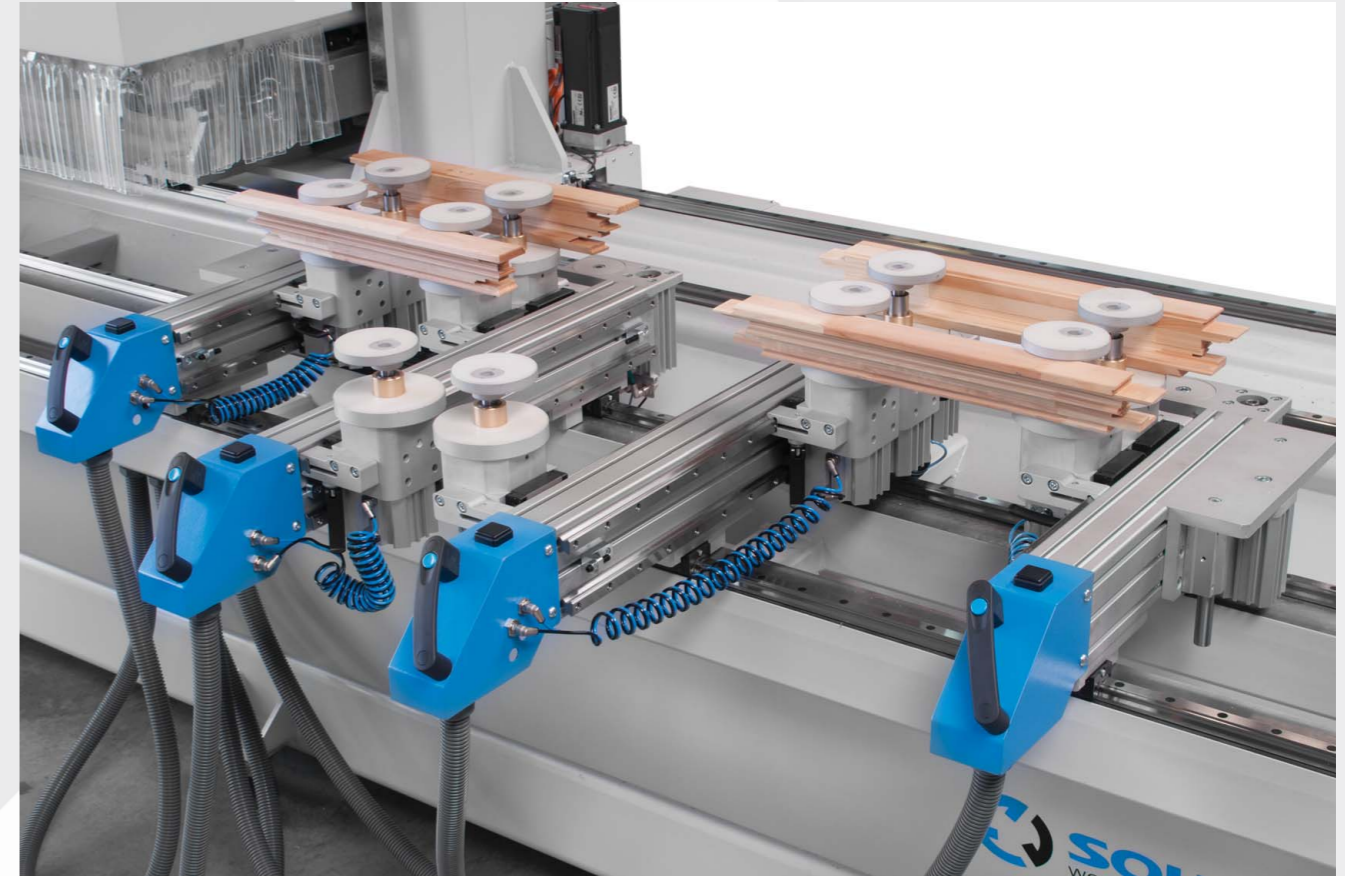

Moveable working tables in positions for arches

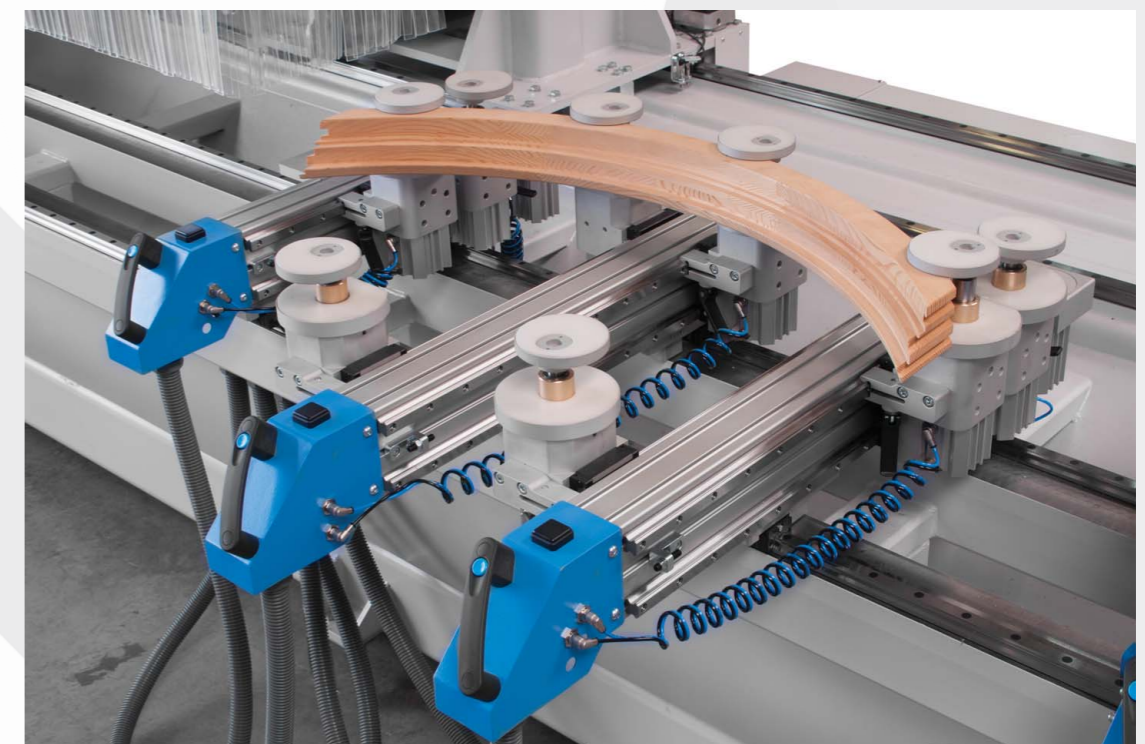

## Examples of processing

The machine is designed for standard operations in window and door manufacturing but the machine can be modified for customer-specific solutions using various accessories.

Different rebates on one piece



Arches



Head and longitudinal drilling for dowel connection



Drilled window hinges



Door 3D and butt hinges



Holes for window handle, mortised for door lock cases, bevelled slots for louvres



## Technical data

- X-axis stroke / length of piece 3200 / 2600 mm
- Y-axis stroke / width of piece 570 / 500 mm
- Z-axis stroke / thickness of piece 350 / 100 mm

### Working units

- vertical electro spindle HSK-F63; 8/9,5 kW; 380V; 24.000rpm; 4 poles; cooling: electric fan; bearings (CC) ceramic front/rear; short nose (C-AXIS for aggregates – optional)
- 5xM10 vertical spindle boring head for 5 drill bits - 1,5kW; 380V
- 2 horizontal milling unit 5,6kW; rpm 0-18000 for bits up to  $\varnothing$  20 mm with HSK 40A quick change system
- Linear tool changer for 6 tools or carousel 12 position toolchanger, aggregate holder as an optional for milling units (optional)

### Control system

- BECKHOFF industrial PC with 15,6" touch screen with Windows Embedded for industrial applications

### Working tables

- 3 moving manually moveable working tables with 4 pneumatic clamps for thickness 50-100 mm.
- 4 moving manually moveable working tables with 10 pneumatic clamps for thickness 50-100 mm.

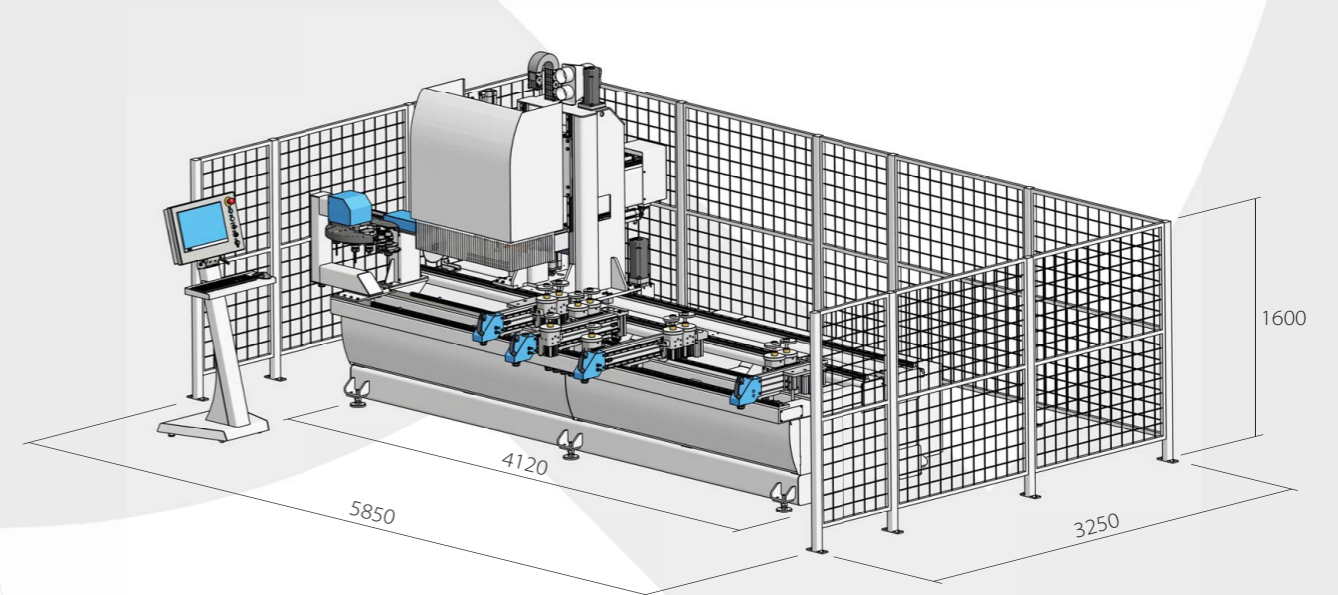



---

**SOUKUP s.r.o.**  
Komerční 518, 251 01 Prague - Nupaky, Czech Republic  
Tel.: +420 241 403 110, E-mail: [info@soukup.cz](mailto:info@soukup.cz)  
[www.soukup.cz](http://www.soukup.cz)